

YANG AND YIN

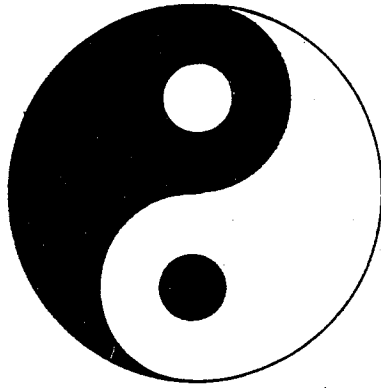

1898:
Drink,



1903:



1906:
Origin:



1933:
Pepsi-Cola
6-ounce
the Pepsi
bottle



1940:
bottle,
glass.

1941:
red, w/



1943:
include
bottle l



1962:
ground

1965:
marks :



1973:
occurin

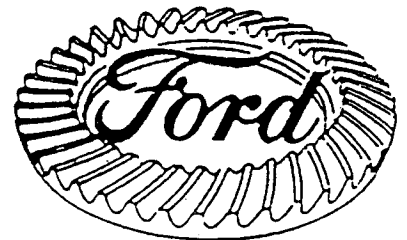

1991:
now in
Pepsi st



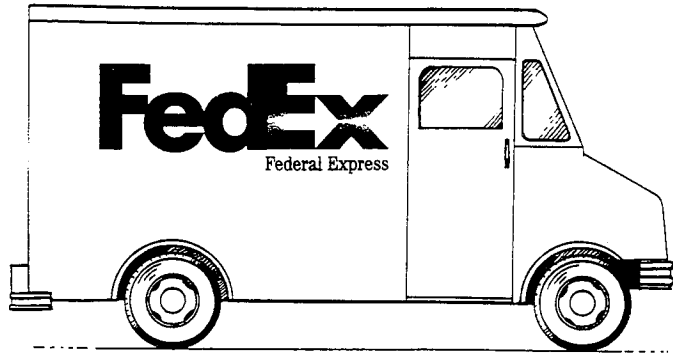

FedEx
Federal Express

Robert A. Miller
 Junior Sales
 Assistant

Federal Express Corporation
 3101 Cahulohoma
 Memphis, TN 38118
 US Mail PO Box 727
 Memphis, TN 38155-0727
 Fax: 901 555 6543

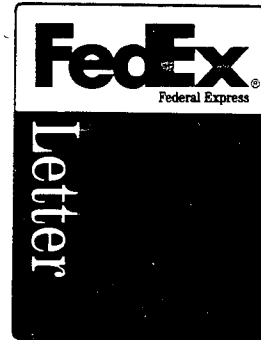
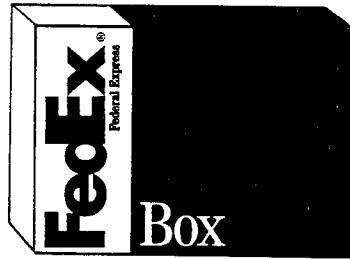
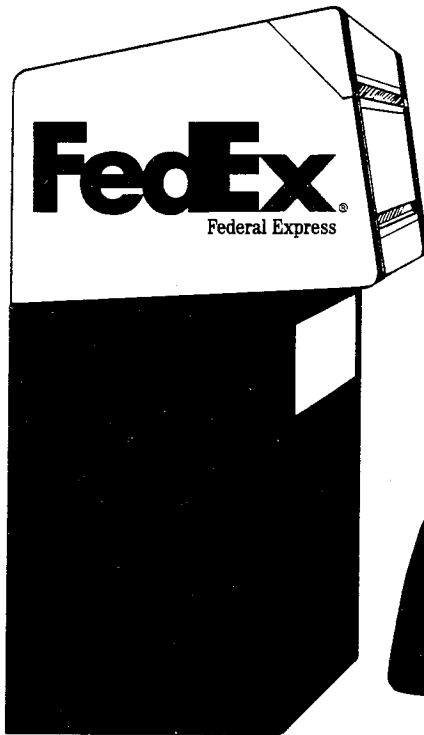
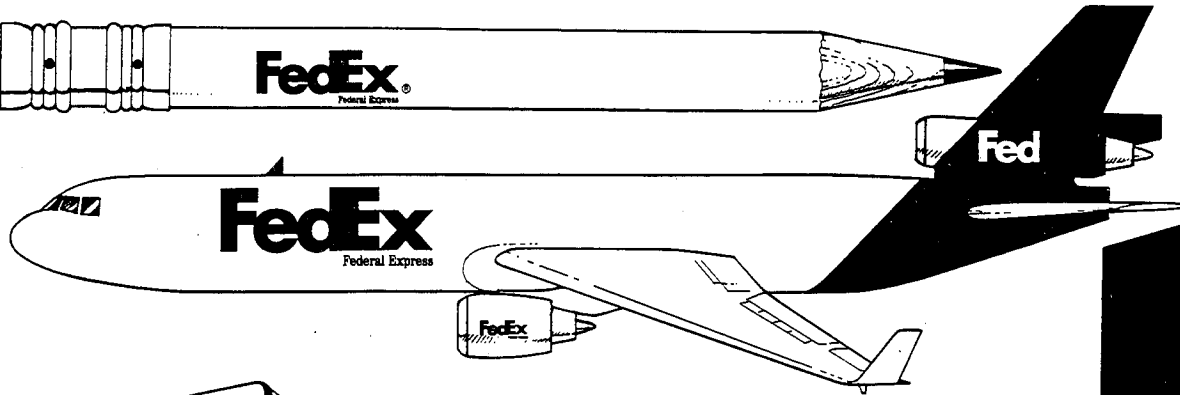
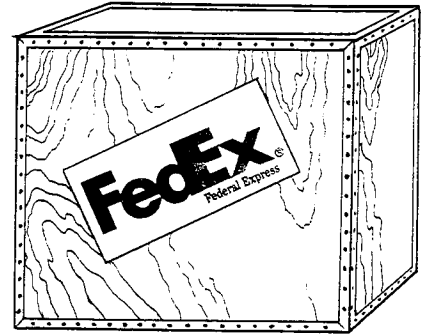

Introducing our new look.

(Boy, we hope you like it. We're putting it on everything.)

We're changing our look to FedEx®. Isn't that what you call us anyway?

FedEx Federal Express *Our Most Important Package Is Yours.*

©1994 Federal Express Corporation

60

MARKS

GRAPHIC DESIGNERS HAVE A PROFESSIONAL RESPONSIBILITY TO BE WELL VERSED IN THE SPECTRUM OF MARKS AVAILABLE FOR SOLVING VISUAL PROBLEMS. MANY CLASSIFICATION SYSTEMS EXIST, DEVELOPED BY GRAPHIC DESIGNERS, ANTHROPOLOGISTS, AND PSYCHOLOGISTS. MOST HAVE POSITIVE ATTRIBUTES, BUT TAKEN TOGETHER THEY CAN LEAD TO CONFUSION AND REDUNDANCY. A FEW BASIC TERMS CAN EFFECTIVELY CLASSIFY MARKS AND FORM A LOGICAL WORKING LANGUAGE FOR DESIGNER, CLIENT, AND PRINTER.

1 **SYMBOLS** · MARKS WITHOUT TYPE USED TO IDENTIFY A CORPORATION, AGENCY OR INSTITUTION. CAN BE LEGALLY PROTECTED.

- **ADVANTAGES:**
 - UNIQUE, SIMPLE GESTALT.
 - QUICK IMPACT
- ◆ **DISADVANTAGES:**
 - COSTLY TO PROMOTE, EXPLAIN.
 - CONFUSION WITH OTHER SYMBOLS

2 **PICTOGRAPHS** · PUBLIC SYMBOLS. USED TO CROSS LANGUAGE BARRIERS FOR DIRECTION, SAFETY, TRANSPORTATION. USE ENCOURAGED BY ALL.

- **ADVANTAGES:**
 - SUBSTITUTE FOR WORDS.
 - INTERNATIONAL.
- ◆ **DISADVANTAGES:**
 - CONFUSION WITH CORPORATE MARKS, CULTURAL CONFUSION.

3 **LETTERMARKS** · LETTERS FORM NAME IN TYPE. USED TO IDENTIFY COMPANY, OFTEN TO SHORTEN LONG NAME. NOT PRONOUNCEABLE.

- **ADVANTAGES:**
 - LETTERFORMS READABLE.
 - ABBREVIATE NAME
- ◆ **DISADVANTAGES:**
 - COSTLY TO PROMOTE, HEAVY VISUAL COMPETITION (LETTERS).

4 **LOGOS** · WORD OR WORDS IN TYPE. IDENTIFY COMPANY, BRAND, PROJECT, GROUP. PRONOUNCEABLE. CAN BE LEGALLY PROTECTED.

- **ADVANTAGES:**
 - PHONIC, UNIQUE, EASIER TO PROMOTE
- ◆ **DISADVANTAGES:**
 - COMPLEX GESTALT, TYPE RELATION PROBLEMS.

5 **COMBINATION MARKS** · SYMBOL AND LOGO USED TOGETHER. ALSO CALLED SIGNATURE. CONSTANT SPACE RELATIONSHIP.

- **ADVANTAGES:**
 - LABEL EFFECT, UNIQUE, SMOOTH RECOGNITION.
- ◆ **DISADVANTAGES:**
 - VERY COMPLEX GESTALT. REDUNDANT.

6 **TRADEMARKS** · ALL OF THE ABOVE. LEGAL NAME FOR UNIQUE MARKS WHICH MAY BE REGISTERED, PROTECTED BY LAW AND SOLD IF DESIRED. FIRST COME, FIRST SERVED.



SYMBOLS

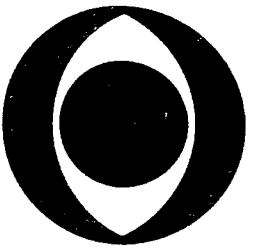

CBS BY W. GOLDEN, N.Y.
 ABSTRACT EYE, PROMOTED VERY HEAVILY SINCE ABOUT 1951, EXTREMELY HIGH RECOGNITION BECAUSE OF EXPOSURE FREQUENCY, ONE OF BEST KNOWN MARKS IN U.S.

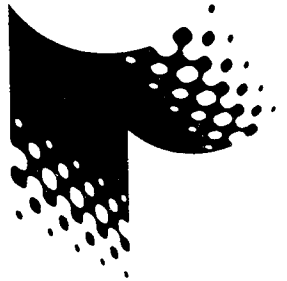

LITHOGRAPHIX BY DON WELER AND DENNIS JUETT, LA.
 SHOWS MOVEMENT OF PRINTED IMPRESSION OFF PRESS, ALSO INCORPORATES HALF-TONE SCREEN, DYNAMIC-MOVES THE EYE FORWARD, TO THE RIGHT.

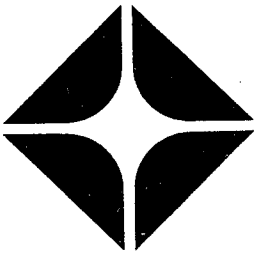

ATLANTIC RICHFIELD COMPANY BY JOHN MASSEY, CHICAGO
 SUGGESTS AN ENERGY "MARK" VERY ABSTRACT, DEMANDS CONSTANT EXPOSURE, ORIENTS ON A POINT SO LAYOUT OF MARK IS CRITICAL.



CSU/CHICO BY GREGG BERRYMAN
 UNIVERSITY MARK, WIDELY EXPLORED, INTENDED TO "SUGGEST" IMAGES OF PLANT, TREE, BOOK, TORCH OF LEARNING... SYMBOLS OF EDUCATION, WHITE SHAPES FLOW OUT OF BOLD CIRCLE.

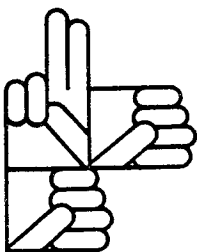

SACRAMENTO HEARING SOCIETY BY ANTOLO BELUZZI, HANDS SPELL OUT SIGN SIGNALS FOR LETTERS SHS, SOCIETY INITIALS, QUIET, LIGHT, LINE WEIGHT, NICE CONNECTION BETWEEN TWO COMMUNICATION SYSTEMS.

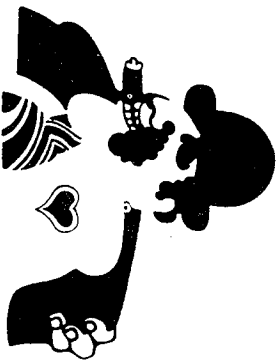

PAPA JOE'S BY DON WELER, LA.
 THIS ILLUSTRATED SYMBOL IS A FASHIONABLE, FRESH/GEOUND STUDY, POTENTIALLY OMINOUS CHARACTER BECOMES FRIENDLY THROUGH USE OF HEART FORM, FOR A DINING/DRINKING EMPORIUM.



CANADIAN BROADCAST CORPORATION BY BURTON KEARER, TORONTO - HIGH DEGREE OF ABSTRACTION, BOLD CAP C FRAGMENTS LIKE A SOUND WAVE, BOLD, DYNAMIC, AND PROMOTED HEAVILY, POSITIVE DIRECTION.

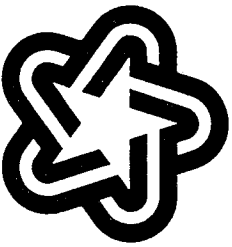

BKENTENNIAL '76 BY BRUCE BLACKBURN, N.Y. A UNIQUE RENDITION OF THE STAR/ STRIPES, GOOD FLOW WITHIN THE SYMBOL, ROUND EDGES SOFT, FRIENDLY.

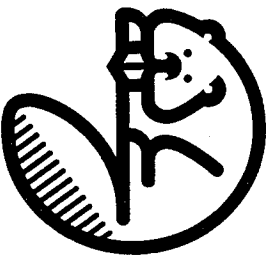

TYBER MOUNTAIN DESIGN BY DOUG POWELL, SACRAMENTO
 BEAVER REPRESENTS FIRM PRODUCING WOOD FURNITURE, CONTINUOUS LINE SYMBOL FEATURES ECONOMY OF FORM AND A COMPACT GESTURE.

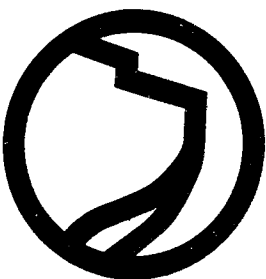

YOSEMITE NATIONAL PARK BY G. DEW SMITH, S.F.
 DEDICTS HALF-DOVE, PARK'S MOST PROMINENT LANDMARK, LINEAR SYMBOL WITH CONTINUOUS WEIGHT, NATURAL SHAPE REDUCED TO ESSENCE.

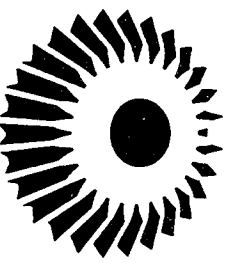

PERFECTION AMERICAN BY GOLDSHALL ASSOCIATES, NORFIELD, IL.
 MAKES STICK GEARS FOR MACHINES, 3-D GEAR, STRONG OPTICAL CHARACTER, GOOD SPACE FLOW THRU THE SYMBOL.

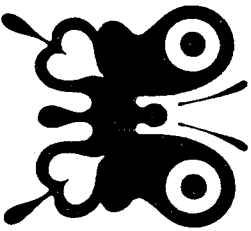

METAMORPHOSIS BY GREGG BERRYMAN, WOMEN'S BOUTIQUE
 SYMBOL, RORSCHACH-LIKE THICK-THIN LINE SHAPES, REVERSE SHAPES SUGGEST FEMININITY, BODY DECORATION.



WOOLMARK BY FRANCESCO SARBELLA, ITALY SINCE 1964
 HAS BECOME ONE OF THE WORLDS MOST FAMILIAR SYMBOLS, ABSTRACTED SKINN OF YARU, SPACE FLOW, OPTICAL STRENGTH, "WOOL-BLEND MARK ITS CHILD.

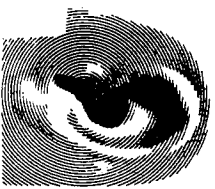

CHARACTER CULTIVATION LABS BY R. KRUEGER, LA. MARK IS DERIVED FROM A PHOTO WITH A CIRCULAR LINE SCREEN, TOTAL SENSORY IMPRESSION, DYNAMIC EAR/SOUND/HEAD, MEMORABLE, YET FACES BACKWARD.



CALIFORNIA CONSERVATION CORPS BY MICHAEL VANDERBYL, S.F.
 MOTHER AND CUB SUGGEST "CARING" FOR THE ENVIRONMENT, EFFICIENT WHITE SPACE BECOMES CUR, DELICATE BALANCE, YET STABLE BASE.